

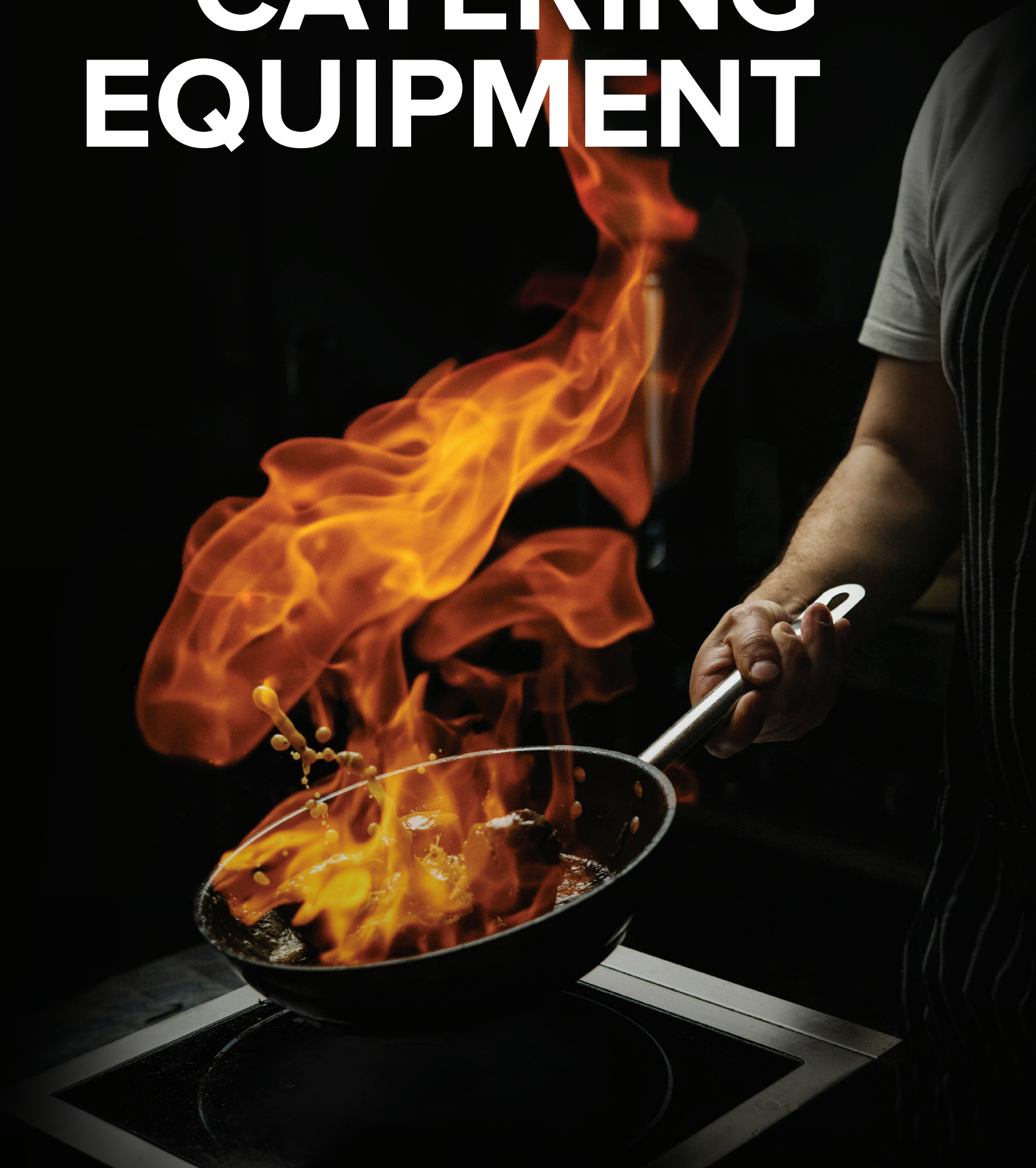

# UNITED / CATALOGUE CATERING EQUIPMENT



# CONTENTS

- Our Profile
- Planning & Design
- Cooking with MBM
- Cooking with RETIGO
- Cooking with ALTO-SHAAM
- Deep Fryers & Broilers  
Chicken Rotisseries  
Oil Filtration Systems
- Food Service Systems
- Wine Cabinets
- Craftsmen on Fire
- Washing
- Induction Units  
Heating Lamps  
Snack Line
- Bakery & Pastry  
Pizza Ovens  
Traditional Pizza Ovens
- Preparation  
Refrigeration
- Bar Equipment  
Ice Machines
- Stainless Steel Constructions
- After Sales Support

Our Profile



# UNITED – CATERING SOLUTIONS FOR THE FUTURE

*United was founded by a team driven by passion for the hospitality industry, professionalism, and over two decades of expertise. Our mission is simple: to redefine how catering equipment is supplied, installed, and maintained—delivering smarter, more sustainable, and future-ready solutions.*

We go beyond equipment. Our services span consultancy, design, supply, maintenance, and staff training, ensuring that every project we deliver enhances both performance and customer experience.

Our headquarters bring everything under one roof: modern offices, a high-capacity warehouse, a fully equipped showroom with a demo kitchen, a dedicated training center, and an advanced maintenance workshop. This integrated approach allows us to innovate, test, and support our partners with efficiency and reliability.

The United Team combines deep culinary knowledge, expertise in space ergonomics, and a solid foundation in electromechanical systems. With this unique blend, we design and implement solutions that maximize efficiency, productivity, and cost-effectiveness—helping our clients stay ahead in a fast-evolving industry.

*We are not just providing equipment—we are building long-term partnerships and shaping the kitchens of tomorrow.*



**CONSULTANCY – DESIGN  
SUPPLY – MAINTENANCE  
STAFF TRAINING**

# PLANNING AND DESIGN

*At United, we believe that the supply and arrangement of catering equipment should be guided by precise planning to ensure seamless functionality, optimize workflow, and eliminate congestion. To achieve this, we have invested in state-of-the-art design software—among the most advanced globally—allowing us to deliver accurate, practical, and visually engaging designs tailored to your needs.*

Our capabilities include:

**2D & 3D ARCHITECTURAL DRAWINGS**  
for clear project Visualization

**ELECTROMECHANICAL LAYOUTS**  
with precise service points for water, electricity, and gas

**HIGH-QUALITY 3D RENDERINGS**  
with realistic material applications and lighting effects, bringing your future space to life

**With our expertise, we transform concepts into efficient, ergonomic, and inspiring spaces designed for performance and growth.**

## What UNITED stands for your business:

- U Understanding**  
We understand the unique needs of every HoReCa business, tailoring solutions that fit each client's vision.
- N Next-Gen Equipment Solutions**  
Cutting-edge catering equipment that combines durability, efficiency, and smart technology to meet the evolving demands of the HoReCa sector.
- I Innovation**  
Bringing the latest technologies and smart solutions to elevate kitchen performance.
- T Training**  
Empowering staff with the skills and knowledge needed to maximize efficiency and safety.
- E Excellence**  
Delivering top-quality service, equipment, and support to ensure long-term success.
- D Dependability**  
A trusted partner for supply, installation, and maintenance—always there when you need us.

Horizontal Cooking



## COOKING WITH MBM

Since 1972, year of foundation, MBM has been characterized by the quality and the ability to offer innovative solutions to improve the work of the foodservice professionals. Today, with a 15.000m<sup>2</sup> plant, 4 horizontal cooking lines, 3 vertical cooking lines and a series of stand alone products, MBM is a reliable and flexible partner, able to provide a complete support to its customers.



MBM is one of the most important brand names in the catering equipment sector.

**MBM unites innovation with Italian design, delivering reliable, bespoke solutions that meet the highest international demands.**



**Gas ranges**

Flex burners with brass caps and self-stabilizing flame for safe, easy cooking. Power adjustable from 1.5 to 5.5 / 7 kW. Suitable for pans up to 40 cm. Dishwasher-size cast iron pan supports.

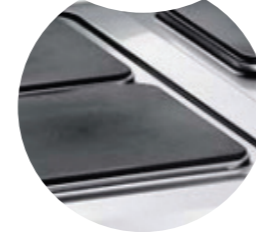

**Electric ranges**

Fast-heating cast iron hot plates with overheating protection, watertight and fixed to the worktop. Available in round, square, or lowered versions (1.5–2.6 kW). Indicator lights show operation.



Cantilever Structure



Induction Hob

Fryer

Pasta Cooker



Boiling Pan

Bratt Pan

Charcoal Grill

Vertical Cooking

# COOKING WITH RETIGO

For preparation of a complete menu, you need not only an experienced team of cooks, but also quality food preparation equipment that will never let you down under any circumstances. Such equipment includes the combi steamer, today an indispensable multifunctional aid to the modern kitchen. RETIGO professional combi ovens feature a functional design refined to the last detail, intuitive control and excellent insulation properties (will not heat the kitchen).

Besides this, they offer advanced functions that include automatic cleaning or economic water and electricity consumption for every model.

## RETIGO



Vertical Cooking

## 7 REASONS TO BUY A RETIGO VISION COMBI OVEN

Hesitating over which combi oven to buy for your business? We'll make it easier for you. Here are seven reasons to choose a Retigo Vision combi oven.

RETIGO



### VISION PERFECT COOKING

Precise temperature and steam control, excellent even cooking, high steam saturation and multi-cooking possibilities are dedicated to satisfy your diners who will always like to come back to enjoy your food. Our mission is dedicated to generate more sales for your facility.

### HIGH VALUE FOR THE BEST PRICE – APPRECIATED BY PROFESSIONALS

Experience and consider the value and benefits related to Vision combi ovens that bring satisfaction to catering professionals like you around the world.

### BUYING FROM THE COMBI OVEN SPECIALIST – THE PERFECT SOLUTION FOR YOUR KITCHEN

From a small snack bar to a large catering facility you can count on the Retigo Vision combi oven solution to match your needs. Benefit from expertise and support when choosing the right combi oven. After-sales support that will optimise your combi oven operation in time.

### VISION DESIGN - APPEARANCE, RELIABILITY AND FUNCTIONALITY

Highly functional and chef-friendly design focused on results and safety for you. Nonmagnetic stainless parts as well as minimum plastic parts used to perform in tough conditions.

### MY VISION CONTROLS – EASY TO USE IN ALL CONDITIONS

Easy to control yet with cutting-edge possibilities saves you time and training costs. Lightning fast response prevents annoying time delays during use. No mechanical control parts to be broken. Precise control even with oily fingers or gloves.

### ADVANCED STEAM GENERATION SYSTEM – OUTSTANDING COOKING RESULTS AND EFFICIENCY

Perfect steam saturation thanks to unique dual-phase water preheating with an in-built heat exchanger. Benefit from desired color, texture, flavor, as well as vitamins and nutrients retained for your diners.

### RETIGO SMART INVESTMENT – FASTEST INVESTMENT RETURN ON THE MARKET

Excellent value for Price with affordable accessories Price optimises your investment. Cost savings related to Triple glazed door glass, 50 mm thick termo insulation, built-in heat exchanger, Water saving system. Low-consumption automatic cleaning will increase your margin potential in years.



Vertical Cooking

# COOKING WITH ALTO-SHAAM

Alto-Shaam's revolutionary Halo Heat technology provides reliable and consistent quality throughout our product line. Whether you need cooking, holding or serving equipment, Alto-Shaam's superior food service equipment has you covered.

Alto-Shaam pioneered the solutions that are essential to profitable foodservice and retail operations around the world. Alto-Shaam partners with customers to innovate and develop new products that will provide high-quality food while reducing energy consumption, food shrinkage and labor costs.

ALTO-SHAAM

*Alto-Shaam has been named Foodservice  
Equipment & Supplies Overall Best in Class 2017*





### Heated Holding Cabinets & Banquets Carts

Alto-Shaam's heating cabinets and banquet carts maximize food quality and minimize waste. Built with Halo Heat® technology, these warming cabinets and carts maintain precise temperatures without drying out or compromising food texture. By extending the shelf life of cooked items, you can significantly reduce food waste and ensure every plate served is as fresh and delicious as when it was prepared. Available in diverse sizes and designs, Alto-Shaam's commercial holding cabinets and heated banquet carts suit operations of any scale, optimizing efficiency while preserving food integrity.



### Carving Station

Buffet at its best with a hot food holding module. Combine your own surface material with a base-heated, drop-in thermal shelf for a perfect counter top blend. Carving stations keep the product hot while maximizing visual appeal.



### Warming Drawers

Alto-Shaam's commercial warming drawers are designed to meet the demands of foodservice operations, ensuring food is held at optimal quality and easily accessible. With Halo Heat® technology, these drawers maintain food freshness without the need for water or harsh heating elements, enhancing food taste and texture. Alto-Shaam's warming drawers empower operators to deliver consistently high-quality dishes while efficiently managing service demands, reducing stress and extending hold times. Elevate your kitchen's performance with Alto-Shaam's food warmer drawers.

### Vector Multi-cook Ovens

- Two, three or four ovens in one
- Flexibility to simultaneously cook a variety of menu items with no flavour transfer
- Control temperature, fan speed and time in each individual oven chamber
- Cook up to two times more food than a traditional convection oven
- Simple operation does not require skilled labour.



### Smokers

Introduce bold, new flavors to your menu. Real smoke comes from real wood. Expand your menu, without adding sodium, fats, or sugars. Experiment with wine, spices or exotic wood to add versatility to your offerings.

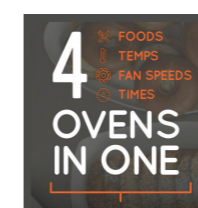

Superior Evenness and Quality



Less Labor



2x More Food than Convection Ovens



Unmatched Flexibility & Variety

# DEEP FRYERS & BROILERS

by IMPERIAL and OFFCAR



Imperial invests in state-of-the-art technology and machinery as part of the commitment to future growth. This provides enhanced efficiencies, lower production costs and consistent, top quality equipment.



Radiant Chargrill



Open-Pot Fryers

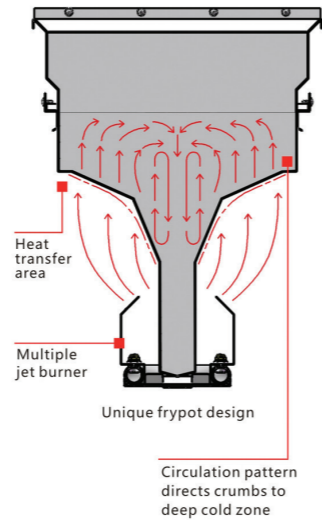

## SuperFry Fryers – The New Star in your kitchen

### Smart Performance

SuperFry adapts to any workload, ensuring consistently high-quality fried food.

### Integrated Filtration

Advanced oil management extends oil life, enhances taste, and cuts costs.

### Energy Efficiency

High-performance heating and Green-Eco mode deliver significant energy savings.

### User-Friendly Interface

Intuitive controls and remote monitoring simplify operations, reduce errors, and boost productivity.



Range in Gas & Electric



# CHICKEN ROTISSERIES

by INOTECH



INOTECH, trademark Sofinor SAS designs, manufactures and markets a wide range of high quality professional rotisseries, using gas or electricity. INOTECH is also a wide range of refrigerated and heating display furniture, allowing the realization of concepts of rotisserie-catering.

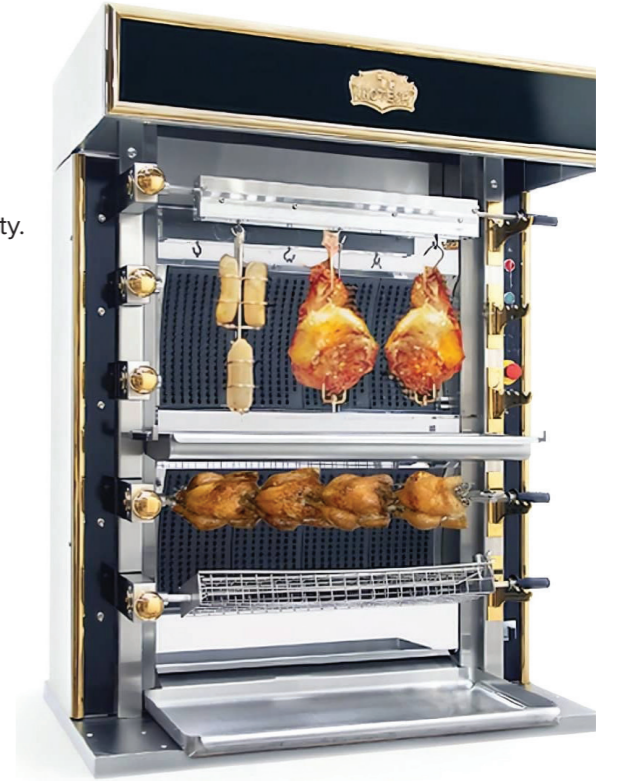

# OIL FILTRATION SYSTEMS

by VITO



- Reduced oil consumption
- Less oil changes
- Less cleaning effort
- Up to 50% savings

VITO® gives you fast return of your investment This can double the lifetime of your frying oil. You will serve optimal fried products with a better taste.

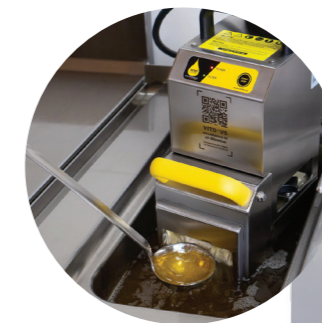



Self Service



Buffet



# FOOD SERVICE SYSTEMS by TECNOSTEEL

The Drop-In line is functionally complete with hot and cold solutions, with wells and top plates pressed, glass overshelves with lighting devices, hot and cold versions. Installable in any furnishing context and easily integrating with any material.

Self service units are ergonomic and extremely flexible. S/s working tops with 1,5 mm thickness, bridge type solution, with open cupboards, hot or cold cabinets, tray-slides, overshelf, warm or cold lighting are many of the accessories which you can have to fit your specific needs.

The correct preservation of food increases its consumption quality.

Organisation ensures the service is second to none.

 **tecnosteel**



# WINE CABINETS

Arka is a high-end wine storage system that blends design, functionality, and technology. Its tall, modular structure enhances the verticality of any space and can form wall units, central islands, or complete wine rooms.

Available in two depths, Arka features either a central refrigeration system or a rear static condenser. The interior can be arranged for horizontal or mixed bottle displays, offering full customization.

Finishes include steel, gold, bronze, or black door frames, wood or lacquered panels, and interiors in silver or black aluminum. Exclusive coverings such as leather, marble, or wood add a refined touch.

Arka transforms wine storage into an elegant architectural element with endless design possibilities.

MOD is a modular wine storage system ideal for homes or commercial spaces, offering flexible installation—free-standing, wall-mounted, or recessed.

It comes in three heights and two depths, with either a central refrigeration system or a rear static condenser. The interior allows for horizontal, reclined, vertical, or mixed bottle layouts, ensuring full personalization.

Exterior finishes include LINEAR FRAMES, MOLDED FRAMES, or FIT CLADDING, in many colors and effects. Interiors are available in silver anodized or black painted aluminum.

MOD stands out for its clean design, versatility, and ability to create distinctive, elegant spaces.

## ARKA

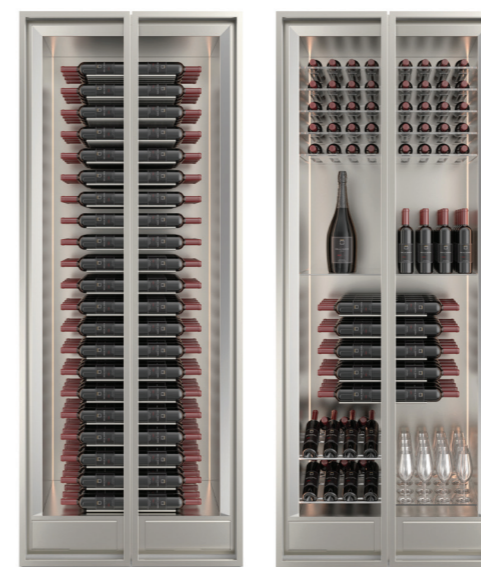

## MOD





Rotisserie



Charcoal Ovens



Duo



Parilla Grills

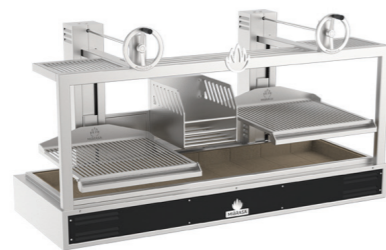

Robata Grills



Hibachi Grill

# CRAFTSMEN ON FIRE!!

by MIBRASA



We are a young, family-run company that places a strong emphasis on quality and durability, ensuring our charcoal grills are built to last.

By using advanced engineering techniques and the highest-quality steels, we strive for maximum precision in every detail — resulting in a product that excels in both performance and versatility.

From welders to chefs, everyone behind Mibrasa shares the same goal: to manufacture the most durable and high-performing grills for professional kitchens in the hospitality and catering industry.





### Glass and Dish Washers

Dishwasher GS 50 ECO made by DIHR is made up for professional and quality cleaning tableware. It is easy wash off not only for dishes, but also for cutlery, tableware and glasses. GS 50 ECO suits perfectly small bars and coffee shops.



### Hood Type Dishwashers

Hood-type dishwasher HT 11 ECO made by DIHR is aimed for professional and qualitative washing dishware. This model cleans dishware and tableware, but is also used in a professional kitchen.

## WASHING by DIHR

With its highly automated production of one machine every 3 minutes DIHR has been for years amongst the very first companies in the world in producing professional Dish and Ware-washers.

DIHR does not only produce standard machines to satisfy your needs, but also designs and manufactures customized solutions for every demand, paying great attention to operating costs and environmental impact.

DIHR gives its contribution to the environment by orienting its products to decrease consumption of water, electricity and chemicals.



### Potwashers

Stop wasting time for soaking and scratching, with poor results. Thanks to the combined blasting of water, detergent and granules, allows the perfect wash of a large variety of overlaid trays, pans and containers.



### Rack Conveyor Dishwashers

A wide range of models with multiple accessories to offer tailor-made solutions for any customer needs. DIHR machines fit into different environments and to the most intense workload. Models are equipped with pre-rinse and rinse. Saves water, rinse-aid and electricity. The water coming out from the rinse-arms is recovered and re-used by the pre-rinse arms That optimizes the performance and reduces waste.

# INDUCTION UNITS by INDUCS

Over 90% of the energy is transferred to the cooking vessel, resulting in cost savings in electricity of up to 40 %. Chefs and operators are delighted with the unique efficiency of these products, combined with their precision control and ability to reach cooking temperatures within seconds.



# HEATING LAMPS

Powerful and economical lamps that maintain the temperature of the dishes in professional catering without drying out the food.



# SNACK LINE



Toaster



Sycloid Toaster



Speed Oven



Waffle Machine



Crepe Machine



Microwave Oven



Water Grill



Gyros Machine



Hovoli



Hotdog



Soup Kettle



Induction Food Processor

# BAKERY & PASTRY



Professional bakeries and pastries require commercial-grade equipment. With experience and knowledge gained over the years in the food industry, we have gathered all the skills and conditions necessary in understanding all the requirements involved in an investment project in the areas of baking and pastry, offering professional equipment for all your needs.



Rack Oven for Bakery and Pastry shops



Retarder cabinet



Deck Oven for Bakery and Pastry shops



Spiral Mixer



Mixer



Dough Sheeter

# PIZZA OVENS by PIZZAMASTER



The main characteristics of PizzaMaster® ovens are economy, safety and stability and very quick recovery. The special design of casing gives the ability to increase the temperature at 340°C in a very short time and keep it stable even when the user opens and closes the door continuously.

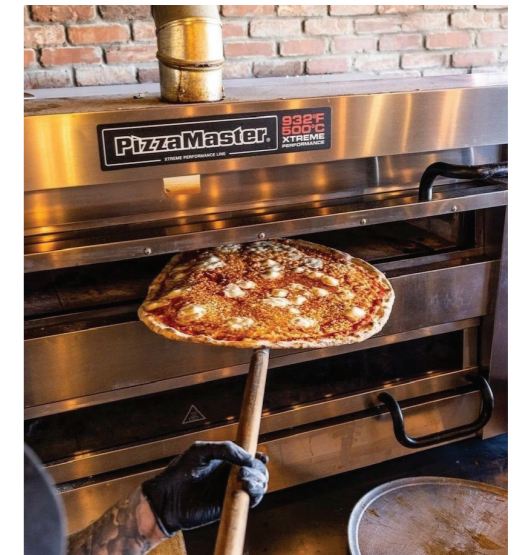

# TRADITIONAL PIZZA OVENS by MAM



## The Round Home oven

This oven can be easily customized with mosaics or paints. You can bake pans with roasted meats, vegetables, cakes, bread and so on besides traditional pizza on the shovel.



## Forno Napoli

This oven is ideal for pizzerias who want to keep the tradition by using an aesthetic shape, while providing an excellent baking quality.



# PREPARATION



Our selection of food preparation equipment comes from some of the top name brands in the industry, ensuring that you're getting a high-quality, high-performance piece of equipment that will be able to meet your busy kitchen demands.

## Meat, Cheese and Vegetable Preparation

- Meat & Cheese Slicers
- Meat Mincers
- Hamburger Press Machines
- Bandsaw Machines
- Vegetable Cutters
- Cutters
- Potato Peelers

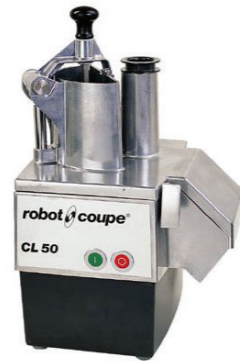

Vegetable Cutter



Robot Cook



Hand Mixer

## Vacuum Packing Machines & Sous Vide Cooker



Vacuum Machine



Sous Vide Cooker

## Slicers & Bandsaw Machines



Volano Machines



Bandsaw

# REFRIGERATION

If you operate any type of foodservice establishment, it's important to have a reliable commercial refrigerator or industrial freezer, so you can hold and store ingredients, prepared food, prepped sauces, and frozen meals. Whether you're looking for a full walk-in cooler or commercial freezer, or you need a smaller undercounter or preparation unit, we have you covered.

## Upright Freezers & Refrigerators



## Counter Refrigerators and Freezers



Freezer Counter



Saladette Refrigerator



Refrigerator with Glass Doors



Back Bar Refrigerator

## Refrigeration & Blast Chillers



# BAR EQUIPMENT



Blender



Frozen Yogurt Machine



Drink Mixer



Hot Chocolate Dispenser



Juice Extractor



Automatic Juice Squeezer

## fiamma

Fiamma, a Portuguese manufacturer since 1977, produces reliable espresso machines and grinders that combine craftsmanship, durability, and advanced technology. Designed for both professional and home use, Fiamma machines are known for consistent performance, solid build quality, and timeless design.



Quadrant



Nau



Astrolab

# ICE MACHINES by ARISTARCO

Aristarco brings over three generations of expertise to the world of professional ice making, combining tradition with innovation to deliver quality you can trust. Proudly 100% Made in Italy, they manufacture their full range of icemakers in their 14,000 m<sup>2</sup> facility in Castelfranco Veneto, overseeing every stage from design and material selection to production and final testing.



### Nugget Ice

Soft, chewable nugget ice perfect for beverages and cocktails. Produced with solid stainless-steel machines with ergonomic ice access and HCFC-free insulation, these nuggets combine consistency and ease of use. Smart electronic controls with self-diagnostics, and accessible filters make daily operation simple and reliable.



### Full cubes

Produced to ensure reliability, efficiency, and crystal-clear results. Shaped with robust stainless steel machines and advanced spray systems, these cubes are perfectly solid and long-lasting. The ice makers feature ergonomic designs, self-diagnostic electronic controls, and front-mounted air circulation, ensuring consistent ice quality even in small spaces.



### Granular ice

Designed for versatility and efficiency. Solid stainless-steel machines with ergonomic access to the ice bins, dual water inlets, and HCFC-free insulation deliver high-quality ice. Front-access filters and frontal air circulation simplify maintenance, ensuring continuous, reliable ice production in



### Dice-shaped ice

Designed for precision and efficiency. Fast production with minimal water and energy use is ensured by vertical copper evaporators and smart controls with self-diagnostics. Durable stainless-steel construction, easy access to filters, and compatibility with multiple storage bins guarantee reliable performance every day.



# STAINLESS STEEL CONSTRUCTIONS

A complete range of neutral units combining innovation, functionality, and design. Crafted from premium stainless steel, each piece can be fully customized in size, finish, and configuration — offering tailored solutions that meet every customer's unique vision.



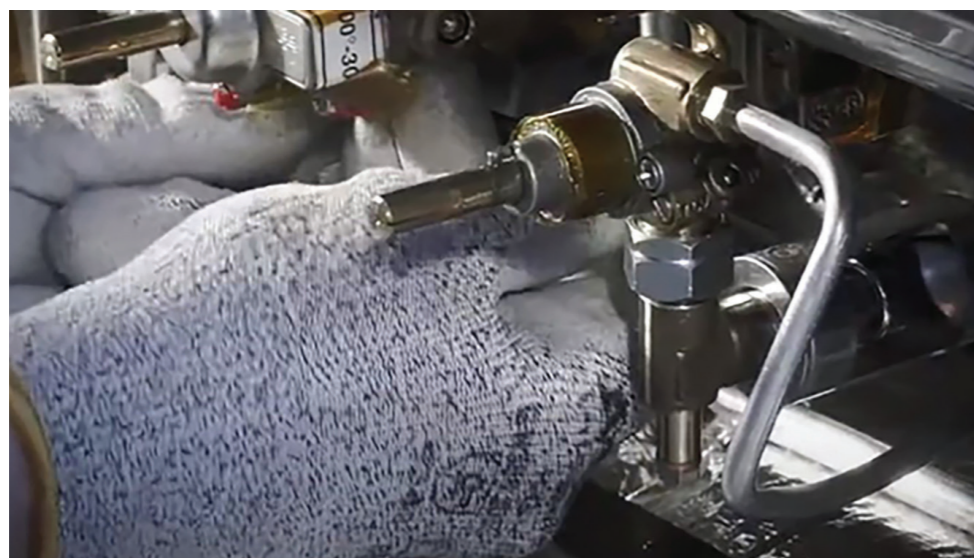

## AFTER SALES SUPPORT

At United, we believe that proper use and maintenance are key to achieving maximum performance and minimizing downtime. That's why we ensure your staff receive professional training from our experienced chefs, while our technical department — equipped with skilled technicians, advanced diagnostic tools, and genuine spare parts — provides expert service that optimizes efficiency, reduces maintenance costs, and extends the lifespan of your equipment.







M & C United Catering Equipment Ltd  
Acharnon 6, 3056, A' Limassol Industrial Area  
P.O. Box: 70728, 3082, Limassol

tel: 77777724 | (+357) 25811155  
fax: 70000024 | (+357) 25754303

email: [info@united-ces.com](mailto:info@united-ces.com)

[www.united-ces.com](http://www.united-ces.com)

